

# Tests Prove Hastings Filters Last Longer and Perform Better.

The word "superior" comes to mind.

**Cellulose/Synthetic Blend Media** increases structural strength, efficiency, and contaminant capacity for longer life.

**Patented Design** combines full-flow and bypass elements creating more holding capacity, longer life, and up to 43% more filtering surface.

**Louvered Center Tube** design has 40% open area compared to standard 15%, maximizing flow through while maintaining strength.

**Radial Post Seal** separates full-flow portion of filter from bypass. One-way valve eliminates filter damage from improper filling.

**Full-Flow Spud Seal** separates clean oil from dirty return oil.

**Heavy-Duty Baseplate** resists leakage with a double-rolled, tuck lock seam.

**Heavy-Duty, All-Metal Housing** provides unequalled strength.

**Steel Coil Spring** maintains a positive load pressure on the adapter seal.



**SAE HS806 lab tests prove Hastings Filters' LF448 surpasses the LF3000 in holding capacity and removal efficiency.**

The unique integral series design of the LF448 provides maximum filtration while the heavy-duty construction ensures dependable operation and superior performance. The Hastings LF448 is the superior choice.

 **HASTINGS**  
PREMIUM FILTERS™

# LF448 Continues to Provide More Efficiency and Life than the LF3000 with Stratapore™ Media

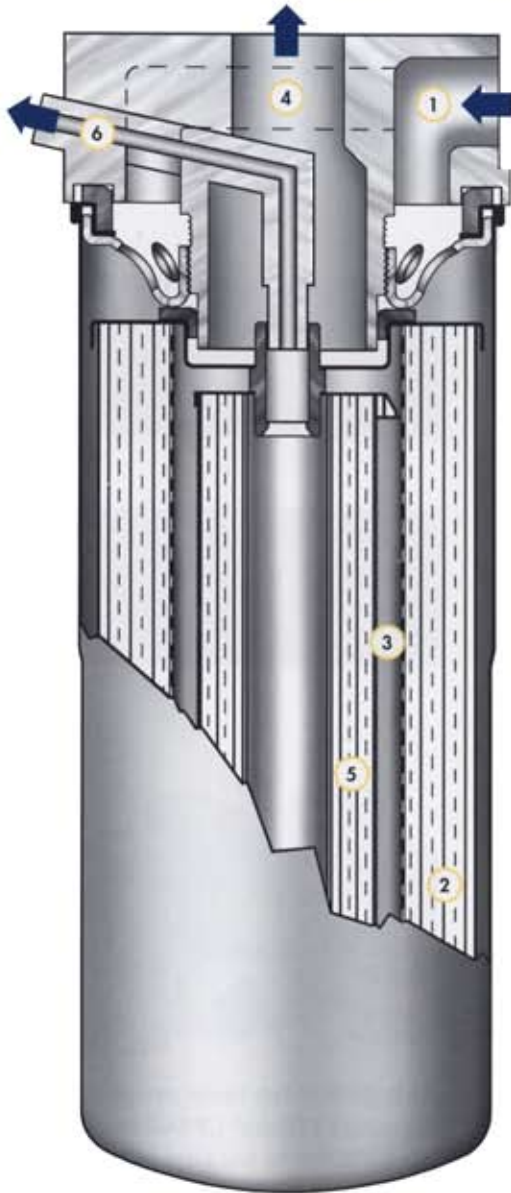

**The results speak for themselves.** Extensive life and efficiency tests and billions of miles of actual use prove the LF448 outperforms the LF3000 (see charts below). The patented series design and the cellulose/synthetic blend media are central to the filter's increased contaminant holding capacity and longer element life. In the LF448, all oil passes through the full-flow element instead of just part of it as with parallel designs. The full-flow/bypass technology of the LF448 offers up to 43 percent more full-flow surface for greater contaminant holding capacity. Higher efficiency means less damage-causing contaminants pass through the filter to sensitive components, leading to longer and more efficient system life. Increased capacity extends filter life without decreasing filter efficiency.

## How the LF448 Works

- All dirty engine oil enters here.**  
Hastings' integral "series" design places the bypass element inside the full-flow element instead of stacking the two elements as in standard "parallel" designs. This allows both elements to occupy almost the full length of the filter housing and provides additional filtration area.
- Oil passes through the full-flow element.**  
All oil passes through the full-flow element instead of just part of the oil as with other combination full-flow/bypass designs. The full-flow element contains glass impregnated cellulose media (glass/polyester/cellulose blend).
- Oil flow is divided.**
- Majority of oil proceeds to the engine to provide lubrication.**
- Remainder of oil undergoes additional filtration in the bypass element.**
- Oil from bypass element returns to the engine sump.**

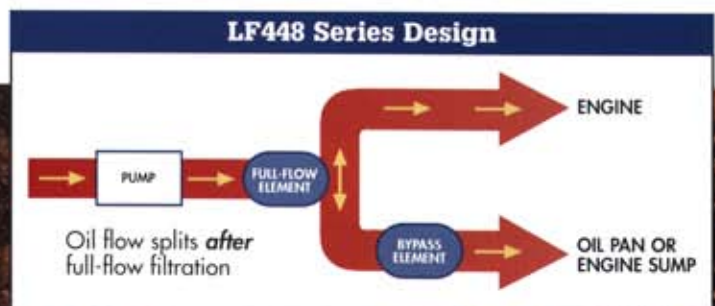
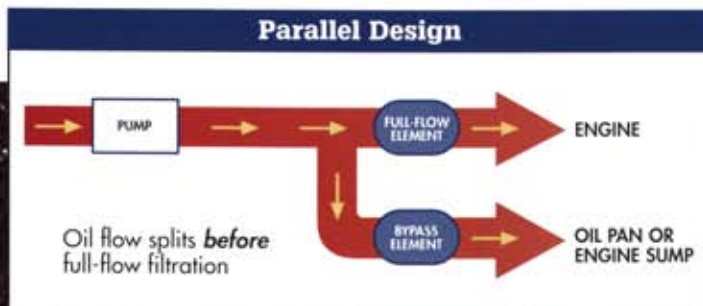
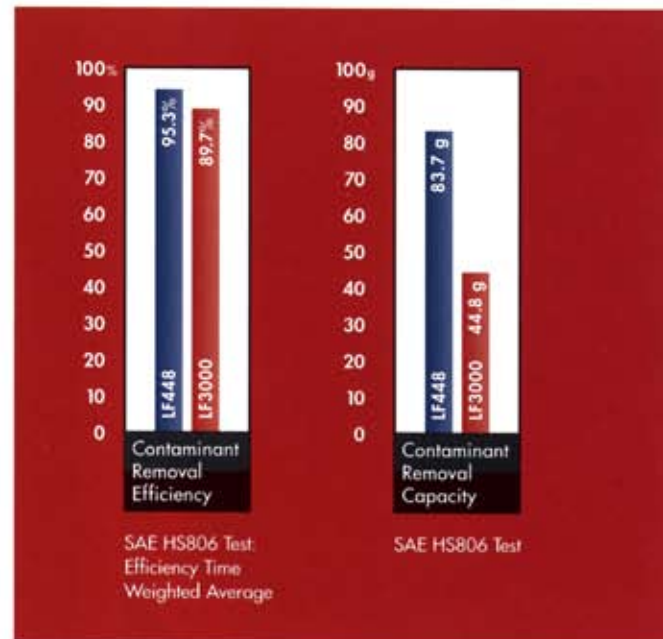

4400 E. Hwy. 30 • P.O. Box 6006 • Kearney, NE 68848-6006  
 Phone: 1-800-887-8836 • FAX: 1-800-210-6906  
[www.hastingsfilter.com](http://www.hastingsfilter.com)  
 © 1998 Hastings Filters, Printed in U.S.A.



F505 R 10/98